



AMERICAN TECHNOS INC.

WWF SUPERSTARS™

© 1989 TECHNOS JAPAN CORPORATION. 1989 TITAN SPORTS, INC. HULK HOGAN™ IS A TRADEMARK OF THE MARVEL COMICS GROUP. LICENSED EXCLUSIVELY TO TITAN SPORTS, INC. WWF, WORLD WRESTLING FEDERATION, AND WWF SUPERSTARS ARE REGISTERED TRADEMARKS OF TITAN SPORTS, INC.

INSTRUCTION MANUAL

AMERICAN TECHNOS, INC.

Invites You to Use

OUR PHONE OR FAX NUMBER FOR
SERVICE INFORMATION CONCERNING THIS GAME.

CALL US FOR PROMPT, COURTEOUS
ANSWERS TO YOUR PROBLEMS.

AMERICAN TECHNOS, INC.

10080 NORTH WOLFE RD., SUITE 372 • CUPERTINO, CALIFORNIA 95014

CUSTOMER SERVICE REPRESENTATIVE

Phone (408) 996-1877

Fax (408) 996-8736

Table of Contents

I. Warranties	
A. Return Merchandise Authorization	1
B. Limited Warranty	2
C. Important Notice	3
II. Set-Up	
A. Location Set-Up	4
B. Complete Dip Switch Setting Chart	5
C. Joystick Assembly	6
D. Control Panel Button	7
E. Coin Door Maintenance	8
F. Monitor PCB and Schematics	9
III. Helpful Hints	
A. Check Points	14
B. Cabinet Specifications	15
C. Edge Connector Pinout	16
IV. Miscellaneous	
A. Notice	17
B. Notes For Reference	18
C. FBI Warnings	19



WARRANTY AND RETURN POLICY

REPLACEMENT PARTS:

AMERICAN TECHNOS maintains a stock of replacement parts for our products. When placing an order for parts, please supply a complete description of the item, quantity required, P.O. number, and shipping information. We attempt to ship orders the day they are received, orders received after 12:00 noon will ship the following work day. We do not have a minimum order requirement at this time, however we certainly appreciate your efforts to consolidate your orders whenever possible.

Payment Terms are NET 30.

RETURN MATERIAL AUTHORIZATIONS:

Material can be returned to AMERICAN TECHNOS only in the following situations:

1. Parts, return for credit. A parts order was processed incorrectly, ie; wrong items were shipped, wrong quantity was shipped, etc.
2. PCB, Return for Credit. A PCB is being returned for credit to satisfy an Advance Exchange transaction.
3. Other, parts are being returned for engineering analysis, etc., only with prior consent of Customer Service or Sales department.

To obtain a Return Material Authorization, please contact AMERICAN TECHNOS' Customer Service department. Describe the transaction and request an RMA number. The outside of the package must be clearly marked with the RMA number. Packages not displaying an RMA number will be returned un-opened.

WARRANTY REPAIRS:

During the initial 90-day warranty, customers who's accounts are current are eligible for an Advance Exchange PCB. When calling for an Advance Exchange PCB, please supply a complete description of the item needed, game serial number for warranty verification, P.O. number, and shipping information. You will be issued an RMA number for the return of the defective PCB.

Terms for Advance Exchanges are NET 15. If the defective PCB is not returned within 30 days, no additional Advance Exchanges will be issued until the offending PCB is returned, or the invoice is paid in full. If the PCB is not returned until after 90 days, the warranty will be voided, and the customer will be liable for all repair charges.

It is our goal to constantly improve and better our services to you. Your cooperation with the above stated policies will help us greatly to reach this goal. If you have any comments or questions, please telephone our Customer Service department. We will make every attempt to tailor our services accordingly.

LIMITED WARRANTY

AMERICAN TECHNOS, INC. ("Seller"), warrants only to the initial purchaser of its products that the items listed below are free from defects in material and workmanship under normal use and service for the warranty periods specified:

- A. Printed Circuit Boards (60) days
- B. Electronic Components (30) days
- C. Television Monitors (30) days

No other parts of Seller's products are warranted.

Warranty periods are effective from the initial date of shipment from Seller to its authorized distributors.

Seller's sole liability shall be, at its option, to repair or replace products which are returned to Seller during the warranty periods specified, provided:

- A. Seller is notified promptly upon discovery by buyer that stated products are defective.
- B. Such products are properly packaged and then returned, prepaid to Seller's plant.

This warranty does not apply to any parts damaged during shipping or handling, or due to improper installation or usage, or alteration. In no event shall Seller be liable for any anticipated profits, loss of profits, loss of use, incidental or consequential damages or any other losses incurred by the customer in connection with the purchase of American Technos, Inc. product.

(WARRANTY DISCLAIMER)

EXCEPT AS SPECIFICALLY PROVIDED IN A WRITTEN CONTRACT BETWEEN SELLER AND PURCHASER, THERE ARE NO OTHER WARRANTIES, EXPRESSED OR IMPLIED, INCLUDING ANY IMPLIED WARRANTIES OF MERCHANTABILITY OR FITNESS FOR A PARTICULAR PURPOSE.

WARNING

**THIS GAME MUST BE GROUNDED. FAILURE TO DO SO MAY
RESULT IN DESTRUCTION TO ELECTRONIC COMPONENTS.**

WARNING: This equipment generates, uses, and can radiate radio frequency energy and if not used in accordance with the instructions manual, may cause interference to radio communications. Operation of this equipment in a residential area is likely to cause interference in which case the user at his own expense will be required to take whatever measures may be required to correct the interference.



"WINNERS DON'T USE DRUGS"

William S. Sessions, Director, FBI

IN COOPERATION WITH THE AAMA AND FBI ANTI-DRUG CAMPAIGN

©1989 TECHNOS JAPAN CORP.

All Rights Reserved

No part of this manual may be reproduced by any mechanical, photographic or electronic process, or in the form of a phonographic recording, nor may it be stored in a retrieval system, transmitted, or otherwise copied for public or private use, without permission from the publisher.

The game play, all graphic designs, this technical manual, its accompanying diagrams, and the display manual are protected by the law.

You may void the game warranty if you do any of the following:

- Substitute non-American Technos electronic parts in the game.
- Modify or alter any circuits in the game by using kits or parts *not* supplied by American Technos.

LOCATION AND SET-UP

INSPECTION:

1. Remove the game from its shipping crate.
2. Inspect the entire outside of it for any signs of damage.
 - Any scratches? dents? cracks?
 - Any broken controls?
 - Just look it over closely and make a note of any signs of damage.
3. Remove the shipping cleats from the bottom of the cabinet.
4. Install the four levelers, one at each corner of the cabinet.
 - Level the cabinet.
5. Open the cabinet and inspect the inside of the game for any signs of damage.
 - Also check to make sure all plug-in connectors on the wire harness are firmly seated.
 - Replug any connectors found unplugged. **DO NOT FORCE PLUGS ONTO CONNECTORS. DO NOT FORCE PLUGS TOGETHER.** If it won't go on easily, assuming the keys are lined up, it either does not belong there or is damaged.
 - Make sure all printed circuit boards (PCBs) are firmly seated in their connectors. These connectors are also keyed. The PCBs will only go into them one way without being damaged.
 - Note the location of the game's serial number.
 - Check all major subassemblies to be sure they are mounted securely.
 - ✓ Power supply
 - ✓ Control panel(s)
 - ✓ T.V. monitor
 - ✓ Other PCBs and/or PCB rack, etc.
 - ✓ Power chassis
6. Make a note of any problems that can't be easily corrected.
7. Call your distributor and/or service man about your problem list.

NOTE: ALL connectors or plugs are keyed so they will only go together when all pins are properly lined up.

Recommended Dip Switch Settings

Dark heavy set letters are recommended by the factory for best game play and most earnings from WWF Superstars.

DIP SWITCH SETTINGS

DIP SWITCH 1

1	2	3	4	5	6	7	8	
								•Coin-1
OFF	OFF	OFF						1 Coin — 1 Play
ON	OFF	OFF						1 Coin — 2 Plays
OFF	ON	OFF						1 Coin — 3 Plays
ON	ON	OFF						1 Coin — 4 Plays
OFF	OFF	ON						1 Coin — 5 Plays
ON	OFF	ON						2 Coins — 1 Play
OFF	ON	ON						3 Coins — 1 Play
ON	ON	ON						4 Coins — 1 Play
								•Coin-2
			OFF	OFF	OFF			1 Coin — 1 Play
			ON	OFF	OFF			1 Coin — 2 Plays
			OFF	ON	OFF			1 Coin — 3 Plays
			ON	ON	OFF			1 Coin — 4 Plays
			OFF	OFF	ON			1 Coin — 5 Plays
			ON	OFF	ON			2 Coins — 1 Play
			OFF	ON	ON			3 Coins — 1 Play
			ON	ON	ON			4 Coins — 1 Play
								•TV Screen
						OFF		Table type use
						ON		Upright type use
								•Screen Invert
							OFF	Normal
							ON	Invert

DIP SWITCH 2

1	2	3	4	5	6	7	8	
								•Degree of Difficulty
OFF	OFF							Normal
OFF	ON							Easy
ON	OFF							Not to Easy
ON	ON							Difficult
								•Sound for Demonstration
		OFF						Sound
		ON						No sound
								•Super Techniques
			OFF					Normal
			ON					Difficult
								•Game Timer
				OFF	OFF			0
				ON	OFF			+15
				OFF	ON			-15
				ON	ON			-30
								•Select Buttons
						OFF		
						ON		3 Buttons
								•Game Clear — Power Up
							OFF	NO
							ON	YES

JOYSTICK

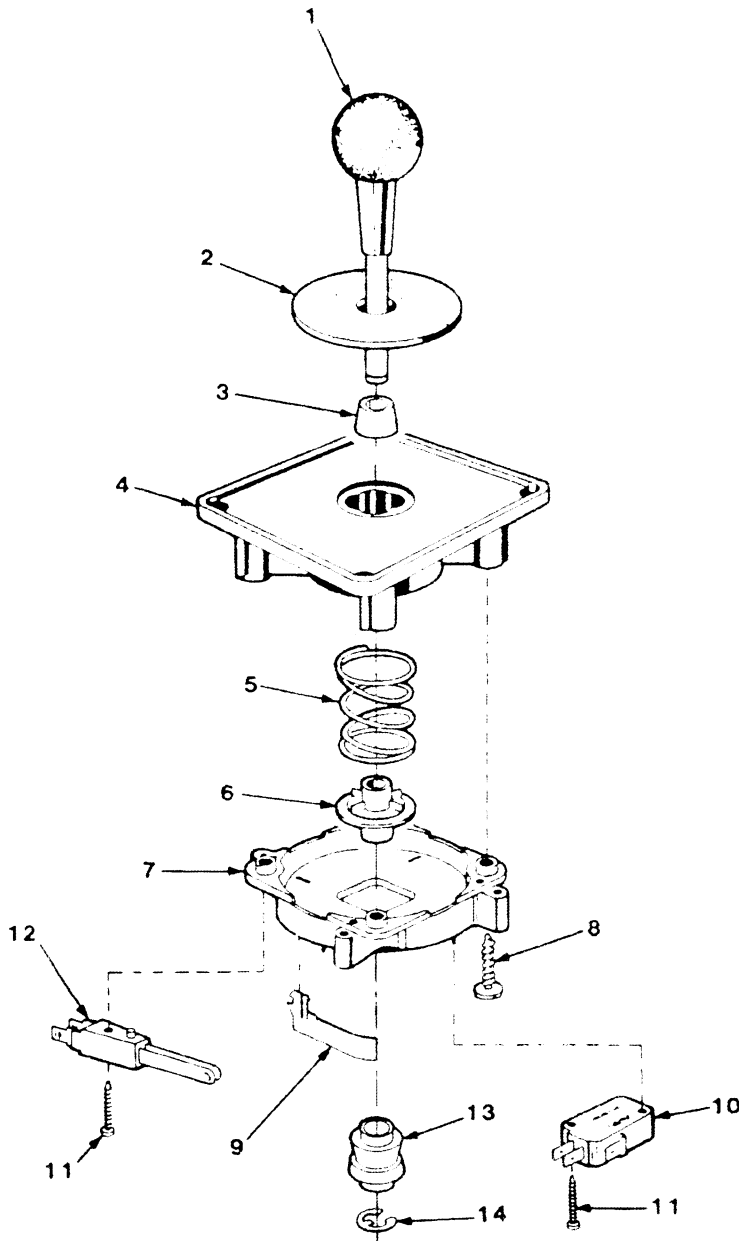

ITEM NO.	DESCRIPTION
1	1.25" Knob & Shaft
2	2" Washer
3	Pivot Cone
4	S.T. Nylon Hub
5	Return Spring
6	Spring Bushing
7	Switch Mount Bracket
8	Screw #10 x 3/4"
9	Switch Protector
10	Micro Switch
11	Screw #4 x 3/4"
12	Side Mount Switch
13	4/8 Way Actuator
14	E-Ring

CONTROL PANEL BUTTON

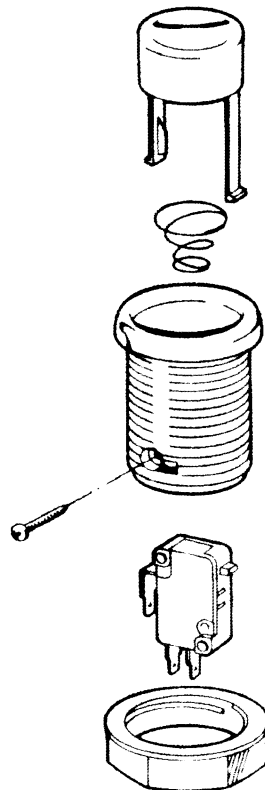
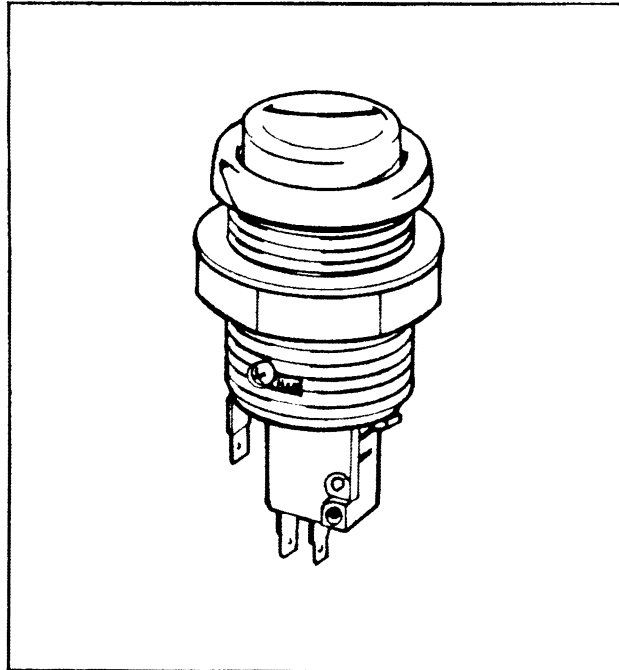

COIN DOOR MAINTENANCE

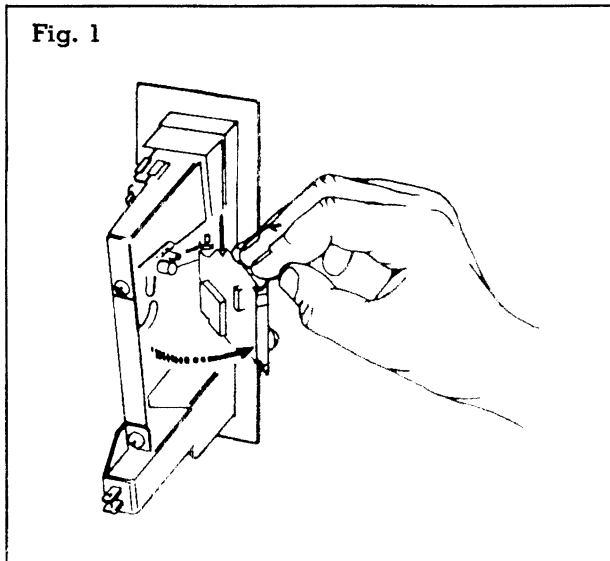

The magnet that is fitted to the mechanism, should be kept clean from foreign particles. The magnet can be cleaned by swinging the gate open. (as shown in Fig. 1). Remove metal filings from the magnet by guiding the point of a screwdriver along the edges of the magnet, such that the filings cling to the screwdriver.

The mechanism can be cleaned by immersing in water using a small brush to clean the mechanism. Rinse the mechanism with boiling water and dry with compressed air.

Note:

Since the Gold Mech relies on coins passing the magnet at a constant speed, the rejector must be free of dirt and grease which may slow down the coins. Do not lubricate the acceptor with oil as this slows down coins.

If the above procedures are not successful, check for worn, bent, or damaged parts and replace where necessary.

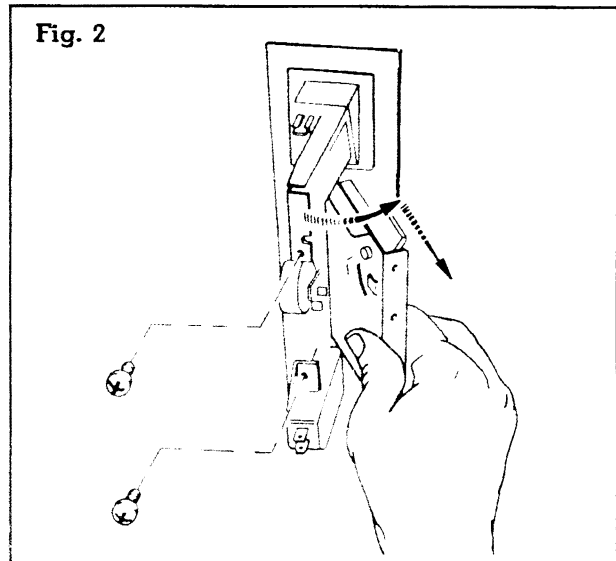

Removal of Mechanism

To remove the coin selector: Unscrew the two screws (as shown in Fig. 2) — swing rear of selector body away from the lock-out side and withdraw.

The Gold Mech Acceptors are designed to require a minimum of maintenance and field adjustment. Coins are checked by diameter and thickness, weight, metal content, bounce, and for ferromagnetic coins such as nickel and steel, a rim test is also used.

Coin Switch

The coin switch comes in two different spring tensions — identified by the color of the plastic boss at the wire's pivot point.

Red: Light tension — U.S. 25¢

White: Heavy tension — heavy foreign coins

HANTAREX MONITOR MAIN BOARD

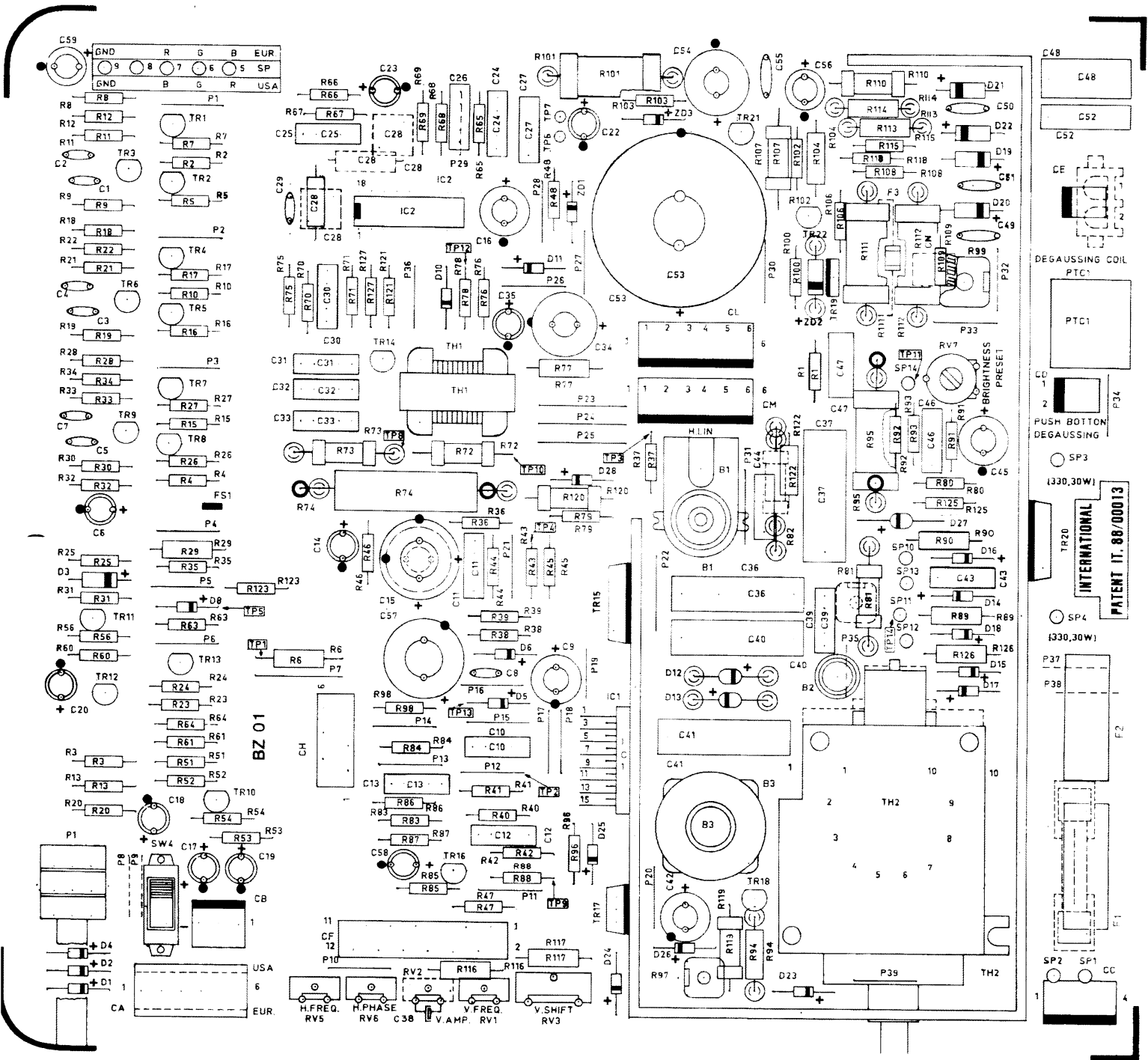

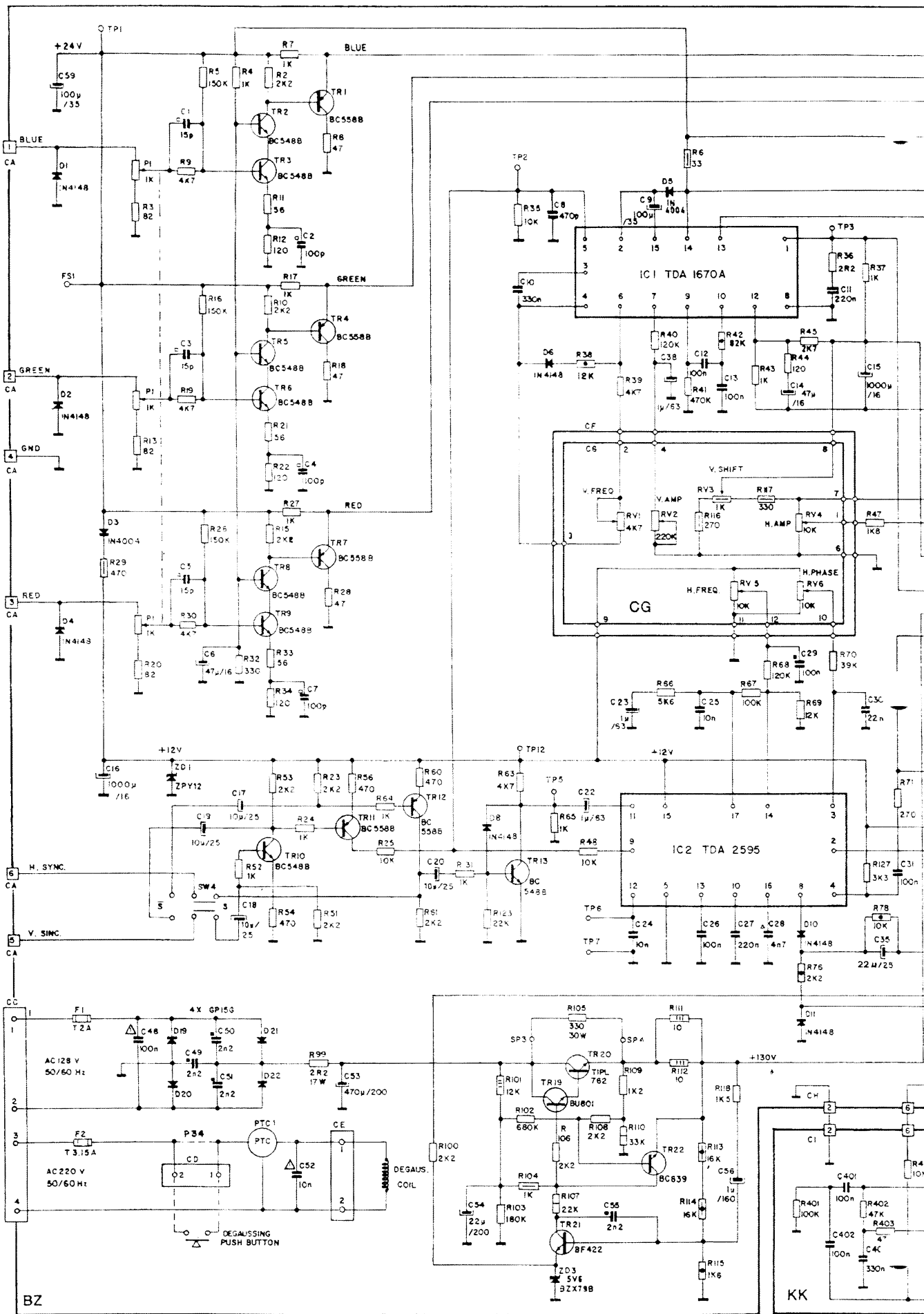

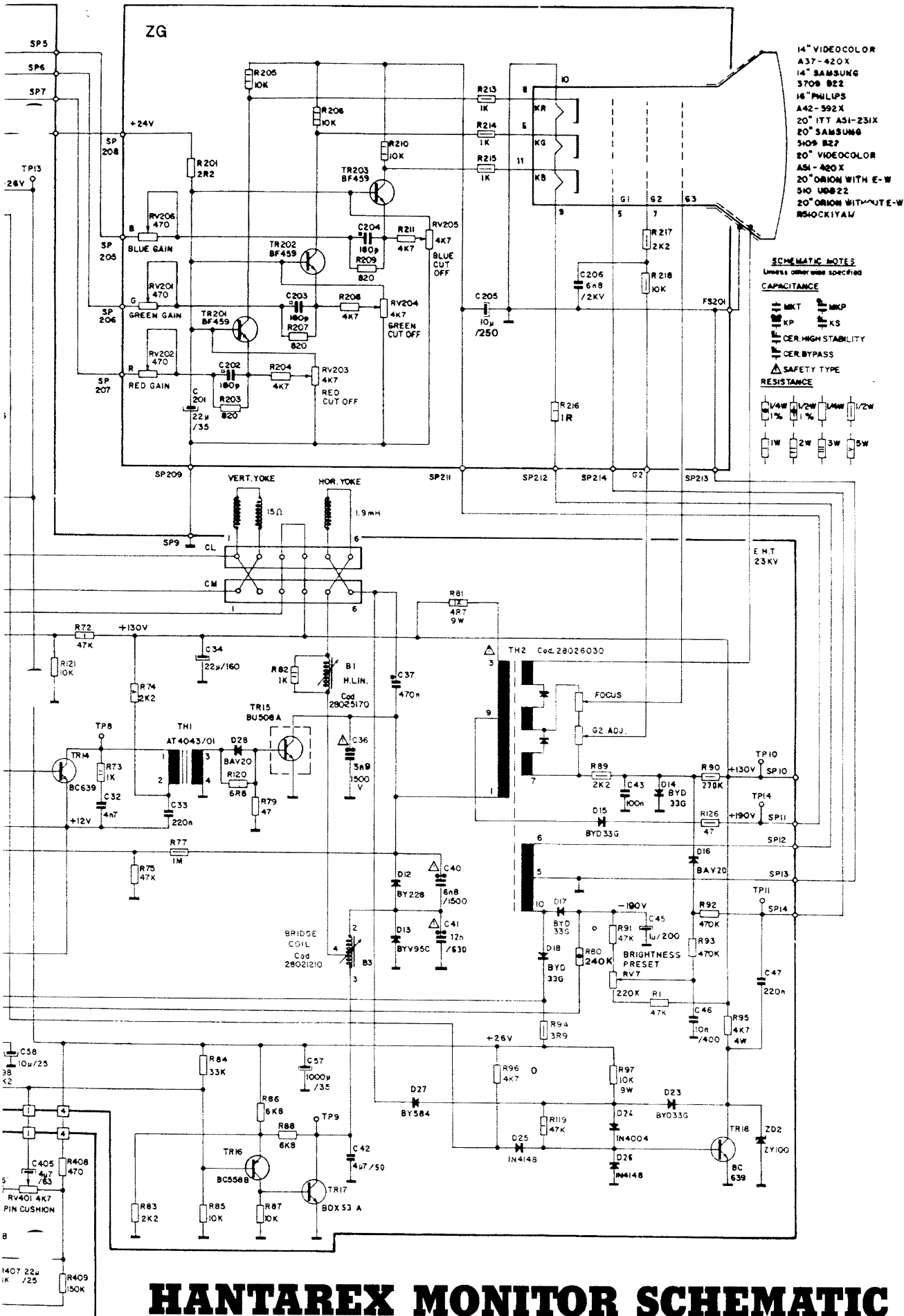

- 14" VIDEOCOLOR A37-420 X
- 14" SAMSUNG 3709 B22
- 16" PHILIPS A42-392 X
- 20" IYT A51-231 X
- 20" SAMSUNG 5409 B27
- 20" VIDEOCOLOR A51-420 X
- 20" ORION WITH E-W 540 UDB22
- 20" ORION WITH E-W-RS SHOCKIYAM

SCHEMATIC NOTES
Unless otherwise specified

CAPACITANCE

- MKT
- MKP
- KP
- KS
- CER. HIGH STABILITY
- CER. BYPASS

SAFETY TYPE

RESISTANCE

- 1/4W 1%
- 1/2W 1%
- 1/4W 5%
- 1/2W 5%
- 1W 5%
- 2W 5%
- 3W 5%
- 5W 5%

HANTAREX MONITOR SCHEMATIC

WELLS-GARDNER MONITOR MAIN BOARD

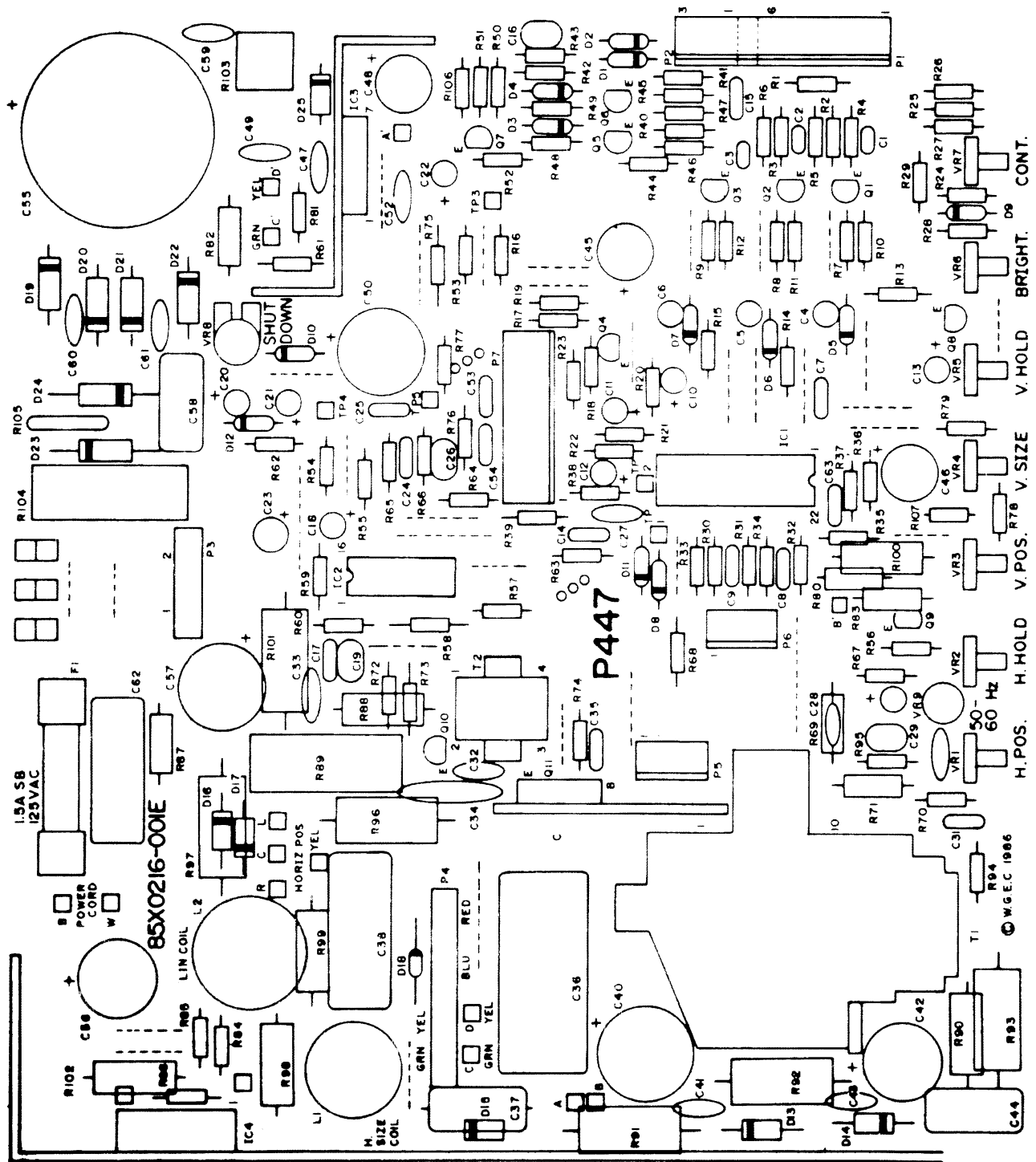

WELLS-GARDNER MONITOR SCHEMATIC

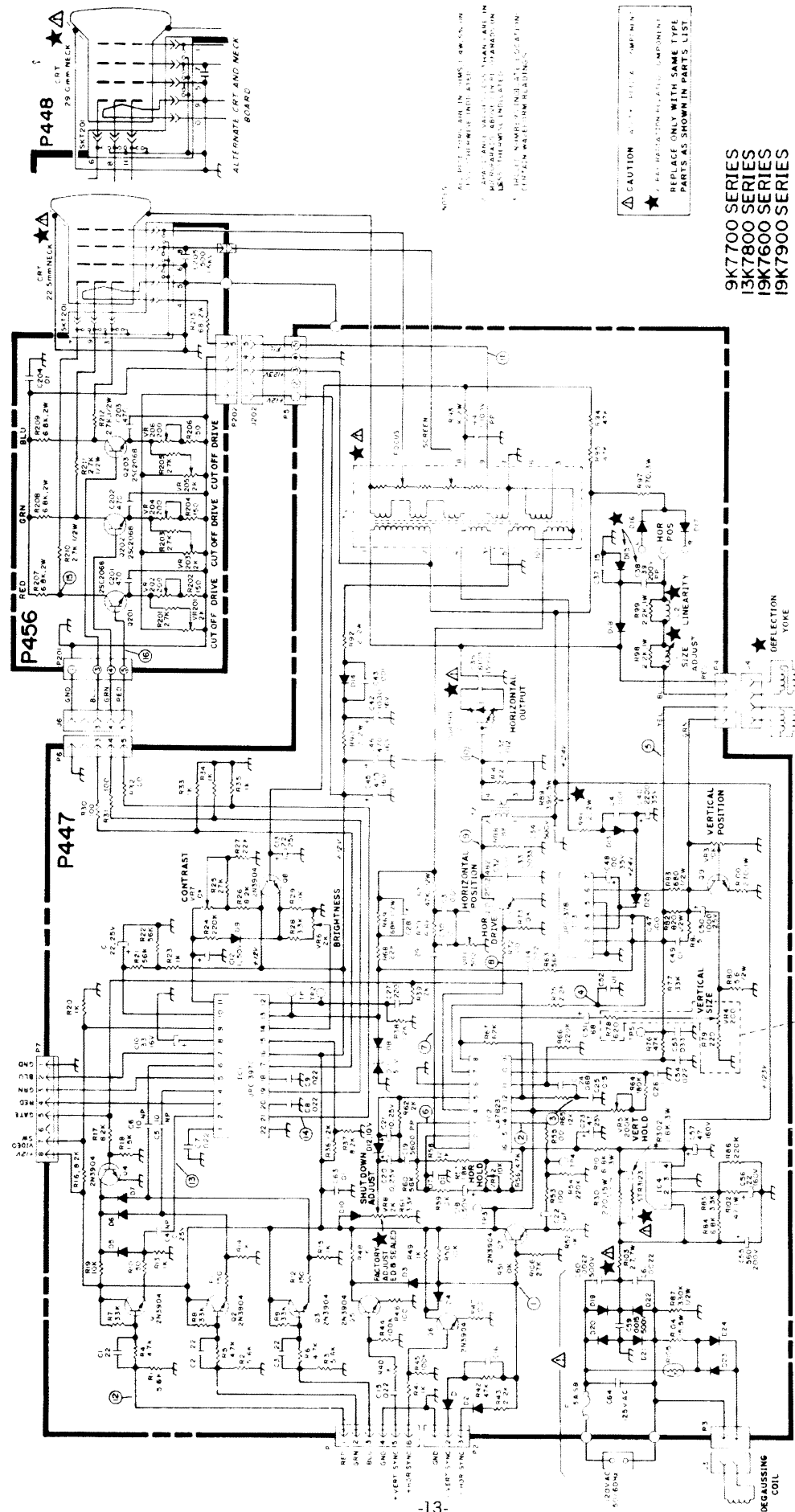

CAUTION - SEE LIST OF COMPONENTS
 REPLACE ONLY WITH SAME TYPE PARTS AS SHOWN IN PARTS LIST

9K7700 SERIES
 13K7800 SERIES
 19K7600 SERIES
 19K7900 SERIES

NOTE: REFER TO OTHER SCHEMATICS FOR CERTAIN INTER-BOARD SIGNALS FOR CERTAIN INTER-BOARD MODELS

RESISTORS ARE IN OHMS UNLESS OTHERWISE SPECIFIED
 CAPACITORS ARE IN MICROFARADS UNLESS OTHERWISE SPECIFIED
 ALL PARTS ARE IN THE LIST UNLESS OTHERWISE SPECIFIED
 * VERY SYNC
 + HOD SYNC
 - HOD SYNC

CHECKPOINTS IN CASE OF DIFFICULTY

PROBLEM/CAUSE-CURE

No Raster/No Video

- Check A.C. line cord
- Check line fuse
- Check monitor brightness
- Check power switch and/or interlock switch
- Check all solder connections on line filter and transformer
- Check for proper orientation of the PCB connector

Raster/No Video

- Check all PCB to monitor connections
- Check power supply voltage on PCB

No Video/Game sounds can be heard

- Check monitor brightness
- Check all PCB to monitor connections

Wrong Colors

- Monitor needs degaussing
- Check for proper wiring between PCB and monitor
- Check monitor adjustment and adjust if necessary

Wavy Picture

- Check monitor ground is properly connected to monitor
- Be certain sync inputs are properly connected to monitor
- Check horizontal hold adjustment

Horizontal/Vertical Roll

- Check horizontal and/or vertical hold adjustments
- Check for proper wiring of sync from PCB to monitor

No Sound

- Check for -5 volts on edge connector of PCB
- Check volume control potentiometer adjustment
- Check for +12 volts on edge connector of PCB
- Check wiring from PCB to speaker
- Check speaker for low resistance between the "+" and "-" tabs

Bad Sound

- Check wiring to speaker for bad solder connections
- Check sound with another speaker

No Switch Input

- Check ground connection to switch/es
- Check wiring between PCB and switch/es for proper connection
- Check switch/es with an ohmmeter to verify proper operation

Switch Operates Incorrect Function

- Check wiring between PCB and switches for proper orientation
- Check wiring for shorts between switch inputs

No Coin Meter

- Check wiring to coin meter
- Check that +5 volts is on "+" side of meter
- Verify a +5 volt meter is used

When coin switch is made and meter pulses, the screen blanks out and/or game resets

- Verify that a meter with a diode is used
- If no diode is built in meter, a IN4004 can be used across the meter.
Cathode to "+" side of meter and anode to "-" side of meter

AMERICAN TECHNOS CABINET SPECIFICATIONS

Width:	25½ in. Installed
Depth:	30½ in. Installed
Height:	72½ in. Installed
Weight:	220 lbs
Line Voltage:	102 to 132 VAC
Monitor:	19 in. Hantarex or Wells-Gardner
Power Supply:	8 amp +5 volts 1 amp 15 volts 1 amp -12 volts
Fuses:	3 amp Primary (AGC 3)
Line Cord:	SPT-2
Marquee Light:	15 watt Fluorescent
Line Filter:	Delta 2DGBAD5
Transformer:	115V 60Hz

WWF SUPERSTARS CONNECTING DIAGRAM

SOLDER SIDE				PARTS SIDE	
GND		A	1		GND
GND		B	2		GND
+5V		C	3		+5V
+5V		D	4		+5V
-5V	with	E	5		-5V
+12V	yellow	F	6		+12V
		H	7		
Coin Counter 2		J	8	Blue	Coin Counter 1
		K	9		
Speaker (-)		L	10		Speaker (+)
		M	11		
Video Green		N	12		Video Red
Video Sync		P	13		Video Blue
Service	F	R	14		Video GND
		S	15		
Coin 2		T	16		Coin 1
GRAY 2P Start (VS Play)		U	17	(2)	1P Start
V 2P Up		V	18	V	1P Up
2P Down		W	19	GREEN	1P Down
2P Left		X	20	GREEN	1P Left
2P Right		Y	21	YELLOW	1P Right
2P Push S/W 1 (Left)		Z	22	ORANGE	1P Push S/W 1 (Left)
2P Push S/W 2 (Right)		a	23	PINK	1P Push S/W 2 (Right)
2P Start (Co-op Play)		b	24		
		c	25		
		d	26		
GND		e	27		GND
GND		f	28		GND

A JAMMA Harness diagram.

But, the difference is that there are 3 kinds of Start S/Ws.

—IMPORTANT NOTICE—

WWF SUPERSTARS

will be available exclusively through
AMERICAN TECHNOS, INC.

All purchases of this game must be made through
American Technos and authorized distributors

—BEWARE OF COPY GAMES—

WWF Superstars will be available first in the U.S. and Canada until all sales and distribution have been completed. Upon completion of sales and distribution in the U.S. and Canada, **WWF Superstars** will be released in limited quantities in Europe.

Anyone offering parallel boards of **WWF Superstars** will more than likely be selling illegal and illegitimate copies, and will be prosecuted accordingly.

American Technos support the efforts of the AAMA and FBI in its anti-drug campaign. The "**Winners Don't Use Drugs**" message will appear in all *legitimate* versions of **WWF Superstars**.

AMERICAN TECHNOS, INC.

10080 NORTH WOLFE RD., SUITE 372 • CUPERTINO, CA 95014
(408) 996-1877 • FAX (408) 996-8736

Notes:

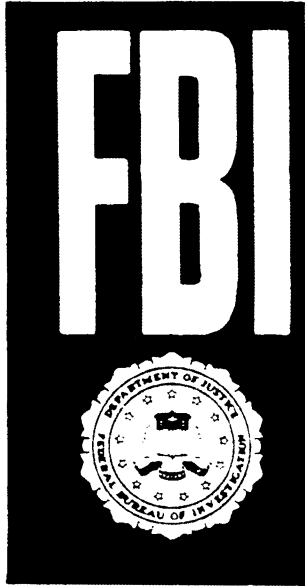

WARNING

Federal law provides severe civil and criminal penalties for the unauthorized reproduction, distribution, or exhibition of copyrighted audiovisual works and video games.

The Federal Bureau of Investigation investigates allegations of criminal copyright infringement.

REGISTER FOR FREE DRAWING



-19-



FROM:

PLACE
STAMP
HERE

AMERICAN TECHNOS, INC.

10080 North Wolfe Rd., Suite 372
Cupertino, CA 95014

AMERICAN TECHNOS, INC.
10080 NORTH WOLFE RD., SUITE 372
CUPERTINO, CA 95014
(408) 996-1877

COMPANY NAME _____

YOUR NAME _____

ADDRESS _____

CITY _____

STATE _____

ZIP CODE _____

AREA CODE & PHONE NO. _____

PRODUCT PURCHASED _____

PURCHASED FROM _____

DATE OF PURCHASE _____

*S/N _____

DO YOU OWN ANY OTHER AMERICAN TECHNOS GAMES? YES NO PLAN TO BUY IN NEAR FUTURE

WHAT TYPE OF ROUTE DO YOU OWN? ARCADE SMALL ROUTE LARGE ROUTE

HOW MANY GAMES DO YOU OWN? _____

COMMENTS: _____

